

EnviroAlert™ EA200/EA400 Quick Start Guide

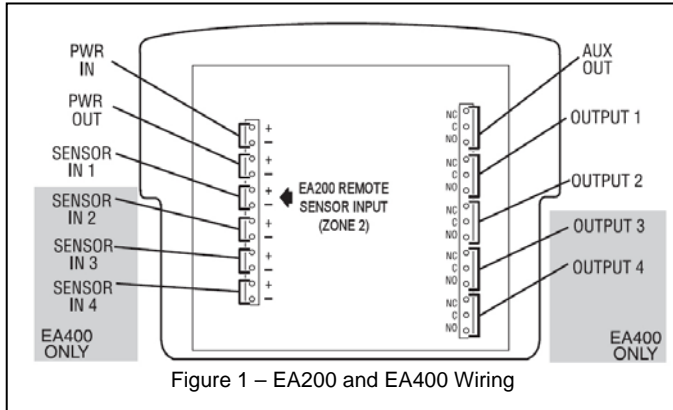

Figure 1 – EA200 and EA400 Wiring

°C or °F	1106, 1107, 1108, 1109, 1109A Older-style polarity-sensitive temperature probes
RED °C or RED °F	M-001-0081 and M-001-0087 High-temp range thermistor probes (32 to 299°F)
BLUE °C or BLUE °F	M-001-0082 and M-001-0086 Low-temp range thermistor probes (-58 to 158°F)
%	M-001-0091 HA-III+ humidity sensor
	M-001-0094 and M-001-0009 Supervised water-detection sensors

Figure 2 – Remote Probe Selections

CURRENT DRAW: EA200 <100mA; EA400 <200mA

Step 1: CONNECT POWER AND SENSOR(S)

Connect power to the PWR IN terminals, as shown in Figure 1. Be sure to observe proper polarity. Connect the sensor(s) to the zone(s) you intend to monitor. You may extend the length of sensor wiring up to 1000 feet using 22AWG twisted pair.

EA200 NOTE: Zone 1 is used for the on-board temperature sensor. **Never install the console in a cooler or freezer.** Remote probes must be programmed on Zone 2. There is only one input for a remote probe on the EA200.

EA400 NOTE: The EA400 does not have an on-board temperature sensor and uses only remote probes.

Step 2: UNLOCK FOR PROGRAMMING

Simultaneously press and release the ENTER and ALARM SILENCE buttons. The “lock” icon should change to “unlocked”.

Step 3: SET THE TIME AND DATE

Press the TIME/DATE button. Using either the INCREASE or DECREASE button, adjust the hours and then press the ENTER button. Continue in this manner to set the minutes, AM/PM, year, month, and day. If power is lost, the time and date must be reset.

Step 4: PROGRAM THE ZONE(S)

1. Press the ZONE button. The zone number will be flashing.
2. Select the zone you wish to program using INCREASE or DECREASE and then press ENTER.
3. Based on the chart above (Figure 2), select the proper sensor type using INCREASE or DECREASE and then press ENTER.
4. Continue in this manner to set the high limit, low limit, optional time delay in minutes (this defaults to 0), and non-alarm relay state (ENERGIZE/DE-ENERGIZE).

NOTE: If you are powering this device from a system with battery back-up, DE-ENERGIZE (the default) generally makes the most sense. If an alarm is desired upon loss of power to the EnviroAlert, select ENERGIZE. However, the normally-open (NO) and normally-closed (NC) contacts shown in Figure 1 will then be functionally opposite.

Step 5: ALARM WIRING

You have the option of using the AUX relay for all-in-one notification or using the individual relay outputs. The AUX relay will change state when any zone is in alarm and can be cancelled for 10 minutes using the ALARM SILENCE button. If you’re using the individual relay outputs, Output 1 corresponds to Zone 1; Output 2 corresponds to Zone 2; etc. If you changed the relay configuration to ENERGIZE in zone programming, your NO/NC contacts will be reversed. The individual outputs are not affected by the ALARM SILENCE button.

Step 6: TEST THE SYSTEM

To test the system, you can either influence the probe’s reading or you can change the limits so that the current reading is outside of the limits. Keep in mind that if a delay is set, you may be waiting for this time to elapse. You may want to go into programming, remove the delay, test the outputs, and then put the delay back in.

ADDITIONAL FEATURES

OFFSET button: The EnviroAlert has the ability to adjust the displayed temperature reading for each zone in order to match it to a known-good reference (± 9 degrees). To use this feature, press the OFFSET button, choose which zone you wish to offset, press ENTER, adjust the value of the offset, and then press ENTER again.

ALARM HISTORY button: This will display the most recent eight alarm events. The display will toggle between the time and date. To scroll through the alarm events, use the INCREASE or DECREASE buttons. Press the ALARM HISTORY button again to exit. This feature relies on the time and date being set correctly. To clear the alarm history, press and hold the ALARM HISTORY button until you see “CLR”.

EA200/400 COMMON MISTAKES AND HOW TO AVOID THEM

“De-Energize” vs. “Energize”

- “De-Energize” simply means that the relay will be off under normal conditions and will switch on when there is an alarm. This is the default state and will correspond with the legend on the circuit board (NO and NC).
- “Energize” means that the relay will be on under normal conditions and will switch off when there is an alarm or if power is lost, providing power-supervision. However, this will reverse your NO and NC contacts. In either case, you still have both sets of contacts. The AUX relay cannot be configured in this way.

Zone # vs. Output #

These directly correspond. Zone 1 uses the Output 1 relay. Zone 2 uses the Output 2 relay. Using Zone 2, but wiring to your alarm panel using the Output 1 relay will not work. To cover all zones with a single relay, use the AUX relay.

“no” in Programming

To program a zone, press the ZONE button, select the zone number, and then press ENTER. You will then see the word “no” flashing. This does not mean “normally-open”. It means “not operational” and indicates the zone is currently off. When you see this flashing, press INCREASE or DECREASE to scroll through your sensing options. If you are trying to turn a zone off, select “no” here.

Temperature Reading is Not Accurate

If the reading does not match your reference, ask yourself the following questions:

- Is it programmed as the correct sensor type (Figure 2) and in the correct zone? If the temperature being displayed isn't even close, this is most likely your problem.
- Has the reference been calibrated and is it known to be accurate?
- Is the reference probe in exactly the same place as the EA200/400 probe? Temperature in a climate-controlled room can vary by several degrees and this is perfectly normal.

If you need to match the EA200/400's reading to a reference, the OFFSET feature can do this. Just make sure that you have a known-good calibrated reference or you may be unintentionally changing an already accurate reading.

On-Board Temp Sensor (EA200 only)

Only the EA200 has an on-board temp sensor and it is programmed on Zone 1. **Never install the EA200 console in a cooler or freezer.** Instead, use a remote probe and program it on Zone 2.

Avoiding False Alarms on a Cooler or Freezer

Both the EA200 and EA400 allow you to program a delay from 0-120 minutes for each zone. When a cooler or freezer door is opened, the temperature will rise and the probe will detect that rise. Freezers periodically need to enter a defrost cycle which may also cause the temperature to rise above your limits. You can set delays so that you don't get nuisance alarms under these normal circumstances. We cannot advise you on what to set for delays or limits.

Always Test the System

It's in your best interest to test the system to ensure proper operation prior to leaving the job site. To test the system, either change the probe's temperature so that it exceeds your limits, or change the limits to simulate an alarm. If you're using a delay, it's best to take the delay out, test the unit, and then put the delay back in.

More information and all product manuals can be found at: www.winlandsecurity.com



**WINLAND
ELECTRONICS, INC.**